

Intelligent Pan-Tilt Unit Real-time Positioning Module

Fully Integrated, Advanced Positioner

The PTU-D100 is a family of modular computer-controlled pan-tilt units designed for intelligent positioning and control of payloads to over 25 lbs. It is designed to support today's sophisticated applications in automated detection and tracking including human and no-human in the loop. It offers compact size, and multiple mounting options for single or multi-part payloads. The PTU-D100 withstands high duty-cycles and offers long-life in harsh all-weather environments for fixed and mobile applications. Key features include:

- Smooth, repeatable motion and rigid design provides steady images in windy environments and smooth visual tracking
- Powerful command set supports real-time detection and tracking applications: absolute angle, relative angle, velocity control, geointing (lat/lon) with GPM option
- Solid and vibration-tolerant for vehicle-mounted applications.
- Wide-range of pan speeds (< 0.0075°/sec. to over 120°/sec.)
- Extremely precise positioning (0.0075°) allows translating object positions to map coordinates accurately
- 360° continuous-pan option including pass-through for multiple cameras and other payload types (Video, IR, Laser)
- Single connector for all video, control, power
- Flexible payload mounting (top or dual-side)
- Computer interface via RS-232/485 or Ethernet (option)
- Fully sealed for outdoor/marine applications (IP67)



Applications

- Long-range / Perimeter surveillance
- Harbor / Port Monitoring Systems
- Laser ranging systems
- Automated video detection & tracking systems
- Industrial automation
- Vehicle & shipboard surveillance systems
- Force Protection
- Antenna pointing



General Features

- Rigid worm gear design. No belts/pulleys.
- Solid and vibration-tolerant
- 360° continuous-pan with pass-through for any payload
- Single connector for all video, control, power
- Flexible payload mounting (top or dual-side)
- Integrated enclosure for custom electronics
- Precise control of position, speed & acceleration
- CE Mark & FCC certified
- Single DC power input

Options

- 360° continuous-pan
- Custom payload brackets
- Geo-Pointing Module
- Ethernet/IP Interface
- Gyro-Stabilization Module (ISM)
- Custom external housing/finish (special order)

Pan-Tilt Performance

	Side Mount	Top Mount
Max Payload ^a	25 lbs.	15 lbs.
Max Pan Speed ^b	120°/second	120°/second
Max Tilt Speed ^b	120°/second	120°/second

^a Over-the top payload assumes COG < 6" from tilt axis; over the side payload assumes balanced COG.

^b Max speed may depend on exact payload configuration and dynamics.

Pan-Tilt Features

Tilt Range	+30° to -90° from level (120° range) (up to +/-90° with side mount)
Pan Range	+/- 175° or 360° continuous (option)
Pan Speed Min	.0075° /second
Pan Speed Max	120° /second
Tilt Speed Min	.0075° /second
Tilt Speed Max	120° /second
Pan Position Resolution	0.0075° (with microstep)
Tilt Position Resolution	0.0075° (with microstep)
Duty Cycle	High duty cycle, or 3-5 million cycles
Acceleration/Deceleration	Trapezoidal. On-the-fly speed and position changes

Power Requirements

Input Voltage	Unregulated 12-30VDC (fastest performance & torque @ 30VDC)
Power Consumption (Measured at 30VDC)	60 W continuous peak (full power mode) 45 W continuous peak (low-power mode (default)) 1 W continuous peak (holding power off mode)

Connections & Communications

Base Connectors	PRIMARY: 19-pin AMP (MIL-C-26482). Includes: PTU-Power (3c) - 9-30VDC + shield PTU-Control (7c) - RS-232/RS-485 Payload Signals (9-13c)
Payload Signal Pass Through	Power (2c): 50VDC max @ 2A max Video (4c): 2 x Video, or 1 x 10baseT Serial/Aux (3-10c): RS-232/422 Custom: various (OPTIONAL)
Computer Controls	RS-232/RS-485 standard; Built-in multidrop RS-485 networking
Control Protocols	DP (ASCII, Binary)

Mechanical

Weight	18.5 lbs. (8.4 kg) (with top bracket)
Dimensions	Pan Tilt Only: 11.2" H x 7.0" W x 7.9" D w/top mount bracket: 12.23" H
Payload Mounting	Single/dual side-mount, top-mount
PTU Mounting	Pedestal mount
Material	Machined aluminum, stainless fittings

Packaging & Environmental

Standards	Designed to IP67
Operating Temperature	-30°C to 70°C
Non-Operating Temperature	-30°C to 70°C
Humidity	100% relative humidity, non-condensing
Ice (Operating)	Sustain operation with 0.25" ice buildup
Dust/Sand (Operating)	Sustain exposure to blowing dust/sand
Wind/Rain/Fog	IP67
Salt Spray	MIL-810F Salt Spray
Color/Finish	Anodize, Black; Custom colors/finish available.
EMI	CE Mark, FCC Part 15, part B Class B
Certifications	RoHS Compliant

Specifications subject to change without notice.

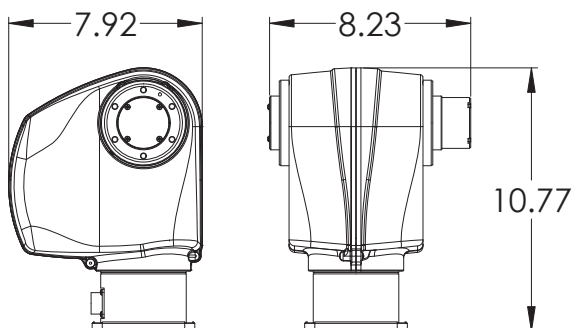

Directed Perception

Advanced and Innovative products for the control and positioning of sensors and precision instruments

890C Cowan Road Burlingame, California 94010

Office 650-692-3900 | Fax 650-692-3930

sales@DPerception.com | www.DPerception.com