



Intelligent Pan-Tilt Unit

Low-Cost Stabilized Pointing for Sea, Air, Ground

Low-Cost Stabilized Pan-Tilt

The PTU-D100-ISM is a family of modular inertially stabilized pan-tilt units designed for intelligent positioning and control of payloads to over 20 lbs. It is ideal for improving images or communications links for mobile applications on aircraft, ground vehicles, and boats.

The PTU-D100-ISM allows real-time control to support today's sophisticated applications in automated detection and tracking including human and no-human in the loop. It offers compact size, and multiple mounting options for single or multi-part payloads. Features include:

- Solid and vibration-tolerant for vehicle-mounted applications.
- Wide-range of pan speeds (< 0.0075°/sec. to over 120°/sec.)
- Low-cost
- 360° continuous-pan option including pass-through for multiple cameras and other payload types (Video, IR, Laser).
- Flexible payload mounting (top or dual-side)
- Computer interface via RS-232/485
- Fully sealed for outdoor/marine applications (IP67)



Applications

- Maritime camera systems
- Airborne Surveillance cameras
- Airborne Antenna systems
- Satellite communications systems
- Wheeled vehicle camera systems
- Ship-to-shore/ship-to-ship communications
- Wheeled vehicle camera systems

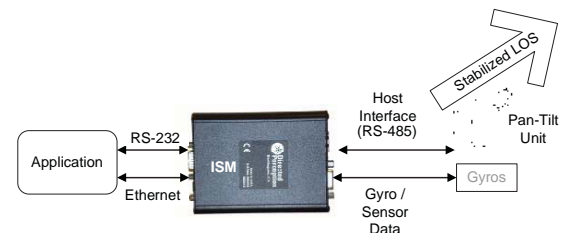

General Features

- 3-axis strapdown gyro design
- Simple serial interface for application control
- Solid and vibration-tolerant
- 360° continuous-pan with pass-through for any payload
- Flexible payload mounting (top or dual-side)
- Precise control of position, speed & acceleration
- CE Mark & FCC certified
- Powerful command set supports real-time detection and tracking applications: absolute angle, relative angle, velocity control, geo-pointing (lat/lon) with GPM option

Options

- ISM Starter Kit (breakout cables, power supply)
- Top Payload bracket
- Side Payload bracket(s)

Pan-Tilt Performance

	Side Mount	Top Mount
Max Payload ^a	20 lbs. (balanced)	12 lbs.
Max Pan Speed ^b	120°/second	120°/second
Max Tilt Speed ^b	120°/second	120°/second

^a Over-the top payload assumes COG 6" from tilt axis; over the side payload assumes balanced COG.

^b Max speed may depend on exact payload configuration and dynamics.

Pan-Tilt Features

Tilt Range	+30° to -90° from level (120° range) (up to +/-90 with side mount)
Pan Range	+/- 180° or 360° continuous (option)
Pan Speed Min	0.0075°/sec with microstep
Pan Speed Max	120° /second
Tilt Speed Min	0.0075°/sec with microstep
Tilt Speed Max	120° /second
Pan Position Resolution	0.0075° with microstep
Tilt Position Resolution	0.0075° with microstep
Duty Cycle	High duty cycle, or 3-5 million cycles
Acceleration/Deceleration	Trapezoidal. On-the-fly speed and position changes

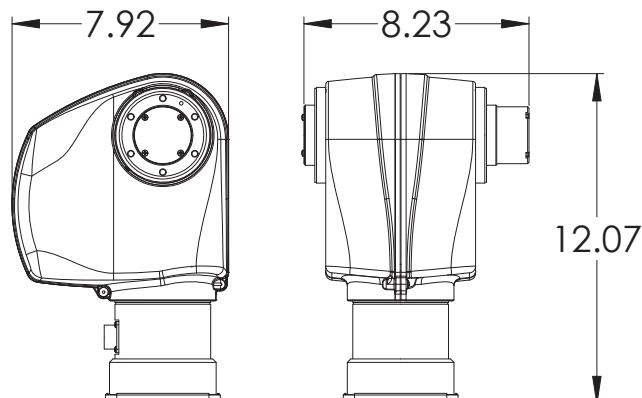

Stabilization

Type	2 Axis (3-axis strapdown gyro, no roll compensation)
Sine-wave Stability Error	< 0.25° sine-wave test (see ISM datasheet)
Typical Stability Error	< 1° under real platform motion
External Control	Accepts pan-tilt commands while stabilized

Power Requirements

Input Voltage	Unregulated 12-30VDC (fastest performance & torque @ 30VDC)
Power Consumption (Measured at 30VDC)	60 W continuous peak (full power mode) 45 W continuous peak (low-power mode (default)) 1 W continuous peak (holding power off mode)

Connections & Communications

Base Connectors	PRIMARY: 19-pin AMP (MIL-C-26482). Includes: PTU-Power (3c) - 9-30VDC + shield PTU-Control (7c) - RS-232/RS-485 Payload Signals (9-13c)
Payload Signal Pass Through	Power (2c): 50VDC max @ 2A max Video (4c): 2x Video or 1x Ethernet (10baseT) Serial/Aux (3-10c): RS-232/422
Control Protocols	DP (Binary) to ISM (See ISM Datasheet)

Mechanical

Weight	19 lbs
Dimensions	Pan Tilt Only: 12.1" H x 8.2" W x 7.9" D
Payload Mounting	Single/dual side-mount, top-mount
PTU Mounting	Pedestal mount
Material	Machined aluminum, stainless fittings

Packaging & Environmental

Standards	Designed to IP67
Operating Temperature	-30°C to 70°C
Non-Operating Temperature	-30°C to 70°C
Humidity	100% relative humidity, non-condensing
Ice (Operating)	Sustain operation with 0.25" ice buildup
Dust/Sand (Operating)	Sustain exposure to blowing dust/sand
Wind/Rain/Fog	IP67
Salt Spray	MIL-810F Salt Spray
Color/Finish	Anodize, Black; Custom colors/finish available.
EMI	CE Mark, FCC Part 15, part B Class B
Certifications	RoHS Compliant

Specifications subject to change without notice.



Directed Perception

Advanced and Innovative products for the control and positioning of sensors and precision instruments

890C Cowan Road Burlingame, California 94010

Office 650-692-3900 | Fax 650-692-3930

sales@DPerception.com | www.DPerception.com